

Owner's Manual

Model

E-16/E-8

RECORDER/REPRODUCER



FOSTEX®

TABLE OF CONTENTS

1. INTRODUCTION	2
2. SPECIFICATIONS	2
3. FEATURE DESCRIPTIONS	5
4. INSTALLATION	10
5. OPERATIONS	13
6. EDITING	17
7. CREATIVE USE OF THE PITCH CONTROL	18
8. ROUTINE MAINTENANCE	19

WARNING: To avoid possible electric shock hazard,
do not expose this appliance to rain or moisture.
There are no user-serviceable parts inside.
Refer servicing to qualified service personnel.

1. INTRODUCTION

This Owners Manual is common to both Models E-16 and E-8 Recorder/Reproducer.

The operating procedures are in Section 3 through 8 and, for checking and repairing, refer to the Service Manual.

Although E-16 is for 1/2" tape at 15 ips (38 cm/s) and E-8 is for 1/4" tape also at 15 ips (38 cm/s), all other features are the same.

The procedures in Section 8 have been limited to adjusting of the pots and therefore, electrical measuring instruments, special jigs and tools are not required. Should further adjusting and repairs become necessary, it is suggested you contact your nearest Fostex dealer or service station.

2. SPECIFICATIONS

Model E-16

Tape	1/2" (12.7mm), 1.5 mil base
Format	16 track, 16 channel
Head	2 heads (Erase, Rec/Play)
Reel size	10-1/2" (270mm), NAB hub
Tape speed	15 ips (38 cm/s), $\pm 0.2\%$
Pitch control	$\pm 15\%$
Line input	-10dBV/0.3V nominal, unbalanced, imp. 30Kohms
Line output	-10dBV/0.3V nominal unbalanced, load imp. 10Kohms or higher
Equalization	15 ips; IEC-1 ($\infty + 35\mu\text{sec}$)
Record level	
calibration	0dB referenced to 320 mWb/m of tape flux
Wow & flutter	15 ips, $\pm 0.05\%$ WTD, $\pm 0.10\%$ UNWTD
Starting time	0.5 sec. or less
Fast wind time	140 sec. for 2500 ft. (762m) of tape
Frequency response	40Hz \sim 18KHz, $\pm 3\text{dB}$
Signal to	
noise ratio	80dB WTD, 60dB UNWTD (With built-in Dolby C)
T.H.D.	Less than 1% at 1KHz, 0dB
Erasure	Better than 70dB at 1KHz
Crosstalk	Better than 50dB/1KHz
Power requirements	120VAC, 60Hz, 155W 220VAC, 50Hz, 155W 240VAC, 50Hz, 155W
Dimensions	430(W) x 445(H) x 235(D) mm
Weight	30Kg. (standard version)

Model E-8

Tape	1/4" (6.3mm), 1.5 mil base
Format	8 track 8 channel
Head	2 heads (Erase, Rec/Play)
Reel size	Up to 10-1/2" (270mm), NAB or EIA/CINE
Tape speed	15 ips (38 cm/s), $\pm 0.2\%$
Pitch control	$\pm 15\%$
Line input	-10dBV/0.3V nominal, unbalanced, imp. 30Kohms
Line output	-10dBV/0.3V nominal unbalanced, load imp. 10Kohms or higher
Equalization	15 ips; IEC-1 ($\infty + 35\mu\text{s}$)
Record level	
calibration	0dB referenced to 320 nWb/m of tape flux

3. FEATURE DESCRIPTIONS

1) HEAD SHIELD GATE

The head shield gate is manually operated. The key lever will lock when pressed toward the head housing and lock disengaged when pressed away from the head.

2) REWIND BUTTON [◀◀]

Depressing this button transports tape at high speed from the right reel to the left reel.

3) FAST FORWARD BUTTON [▶▶]

Depressing this button transports tape at high speed from the left reel to the right reel.

4) STOP BUTTON [■]

All modes of REWIND, F.FWD, RECORD, PLAY, LOCATE 0, and LOCATE 1 will be cancelled and tape stopped when this button is depressed.

5) PLAY BUTTON [▶]

Depressing this button puts the recorder in the play mode.

6) RECORD BUTTON [REC]

a) With more than one and up to 16 (8) RECORD TRACK buttons depressed, simultaneously depressing both RECORD and PLAY puts the tracks thus assigned in the record mode.

b) With more than one and up to 16 (8) RECORD TRACK buttons depressed, and with the transport in the PLAY mode, simultaneously depressing both RECORD and PLAY puts those tracks thus assigned to the record mode (punch in).

7) LOCATE 0 [▶▶0◀◀] AND LOCATE 1 [▶▶1◀◀] button

When either the LOCATE 0 or LOCATE 1 button is depressed, the tape will search at F.FWD or RWD to the zero-second position on the timer, when LOCATE 0 is depressed, or when a tape position has been put into the memory by depressing the MEMORY 1 button, then the transport will enter the STOP mode upon reaching the objective point.

8) AUTO PLAY [AUTO▶] BUTTON

When this button is depressed, the LED at left of this button will be lit. When this LED is lit, the transport automatically enters PLAY mode at coming to a stop by the functions of the LOCATE 0, LOCATE 1 or the AUTO RTN button.

9) AUTO RTN [1◀◀2] BUTTON

The LED at left of this button will be lit when it is depressed. When this LED is lit, the tape in the PLAY mode in the section between MEMORY 1 and MEMORY 2 positions, will automatically go into RWD upon reaching the MEMORY 2 position and stop at arriving at the MEMORY 1 position.

If the Auto Play button also is depressed beforehand, it will automatically enter PLAY mode from the above stop mode.

NOTE: The MEMORY 1 tape position will normally be located ahead of MEMORY 2. If this relationship is reversed and the REPEAT button is depressed, the tape timer LED will blink to indicate an error.

10) RECORD TRACK SELECTOR

These 16 (8) pushbuttons determine whether recording can commence on a given track.

The specific function also depends on whether the tape is stopped, or is advancing in the record ready mode.

a) If tape is stopped, depressing a RECORD TRACK button places the corresponding track in the record ready mode, and the LED (12) above that RECORD TRACK button will blink.

If the RECORD button only is depressed, the meter indications and signals from the OUTPUT jacks will change from tape out to input monitor, only for those channels whose RECORD TRACK buttons are depressed, and if the INPUT MON switch is not depressed, the INPUT

Wow and flutter	15 ips; $\pm 0.05\%$ WTD, $\pm 0.10\%$ UNWTD
Starting time	0.5 sec. or less
Fast wind time	140 sec. for 2500 ft. (762m) of tape
Frequency response	40Hz ~ 18KHz, ± 3 dB
Signal to noise ratio	80dB WTD, 60dB UNWTD (With built-in Dolby C)
T.H.D.	Less than 1% at 1KHz, 0dB
Erase	Better than 70dB at 1KHz
Crosstalk	Better than 55dB/1KHz level (all tracks in REC mode)
Power requirements	120VAC, 60Hz, 120W 220VAC, 50Hz, 120W 240VAC, 50Hz, 120W
Dimensions	430(W) x 445(H) x 235(D) mm
Weight	30Kg. (standard version)

Dolby Noise Reduction manufactured under license from Dolby Laboratories Licensing Corporation. "Dolby" and the double-D symbol are trade marks of Dolby Laboratories Licensing Corporation.

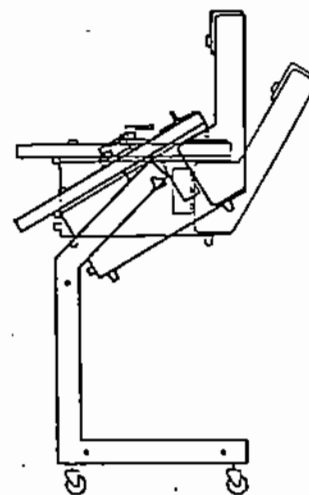
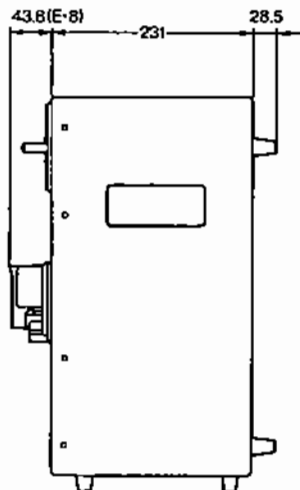
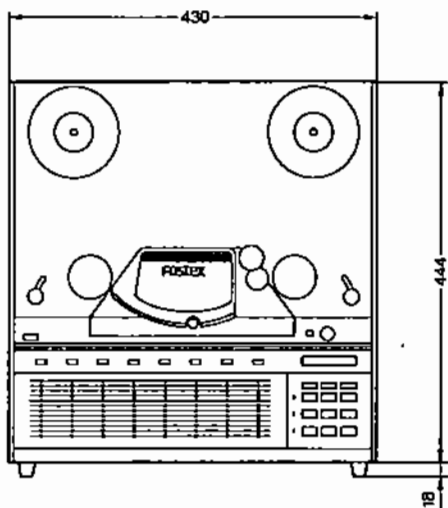
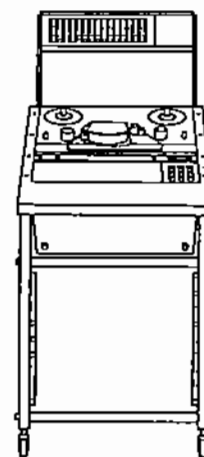
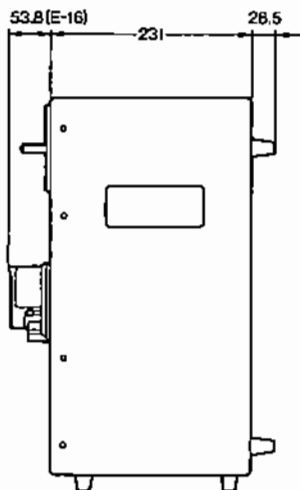
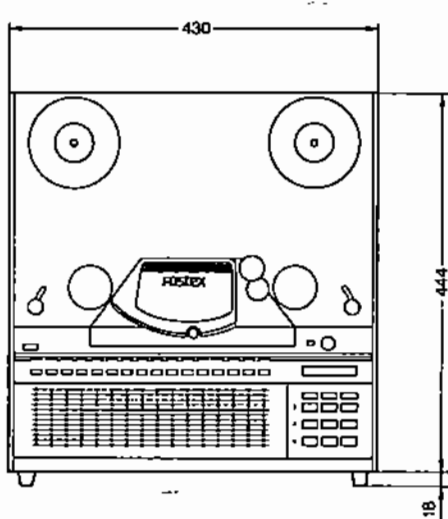

Standard version

Rack mount and meter bridge

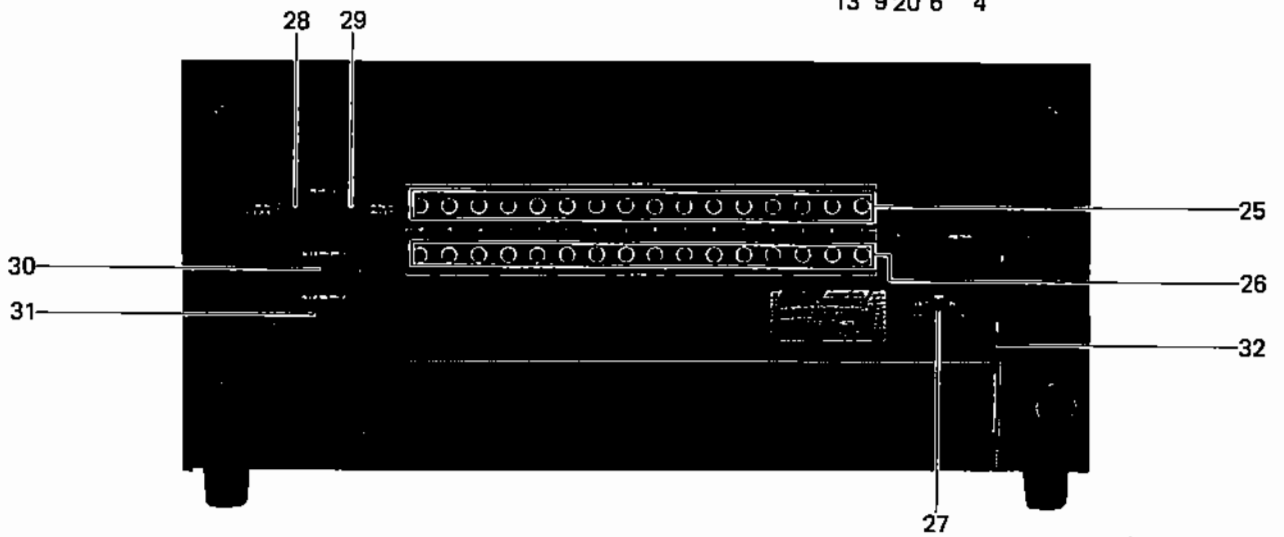
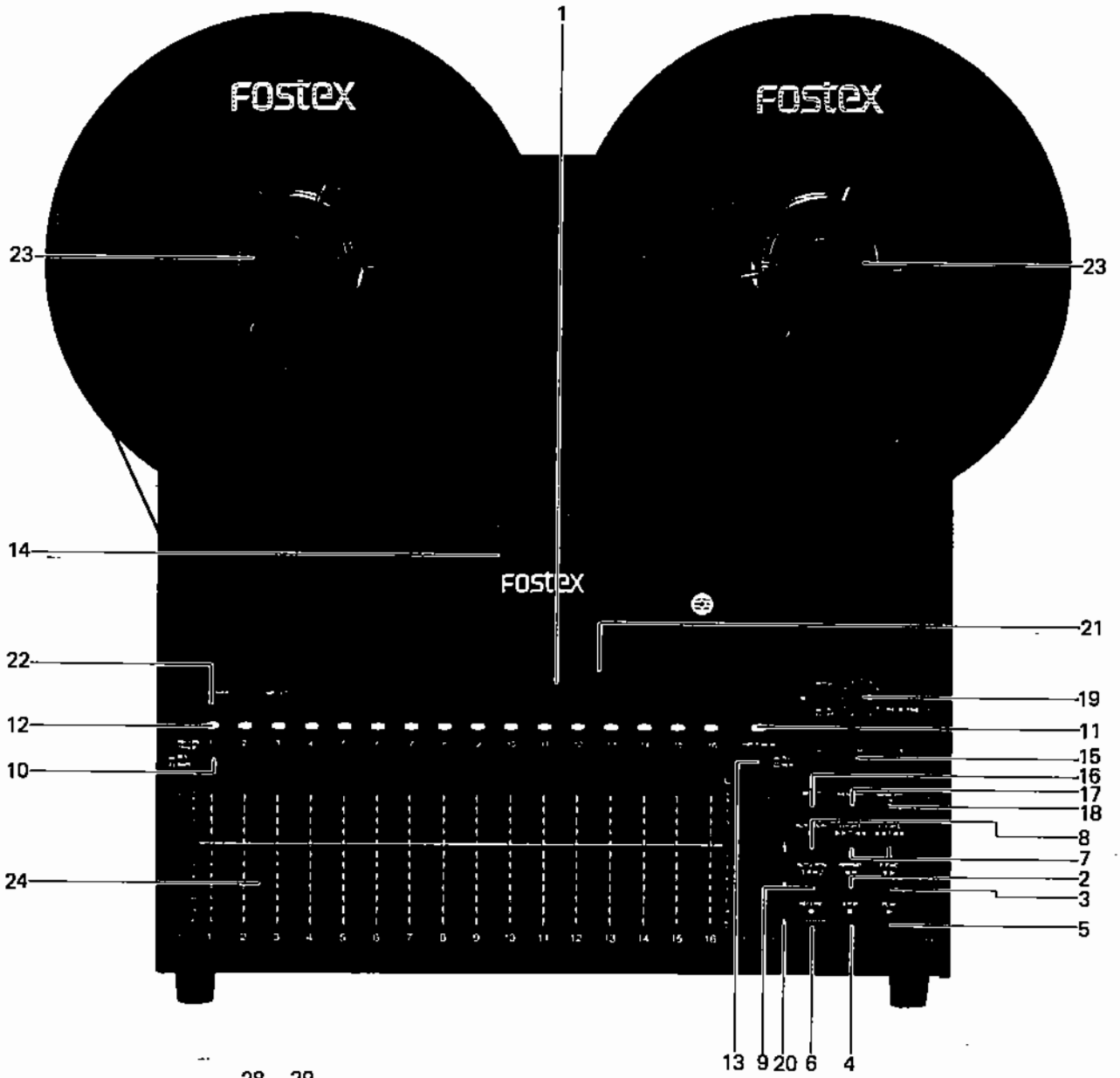

MON LED (11) will change to blinking. This mode will be cancelled by depressing the RECORD button again, but will not be cancelled by depressing any other button.

If the RECORD and PLAY buttons are subsequently depressed, the tape begins recording, the RECORD TRACK LED stops blinking and remains on, and the RECORD LED also lights. Meter indications and signals from the output jacks will carry the input signal of the channel(s) which are in the record mode by this operation; the other channel(s) will remain in the tape out signal monitor mode.

- b) If tape is rolling in the PLAY mode, depressing a RECORD TRACK button has the same effect as in a), above; it readies the track for recording. In this condition, the meter indications and signals from the output jacks will be tape out for all channels.
- c) If tape is rolling in the record ready mode (i.e. RECORD and PLAY buttons have been depressed), the RECORD LED adjacent to the RECORD button will be a green light.

Subsequent depression of a RECORD TRACK button immediately causes that track to enter record mode; the RECORD LED (now lights red) and the RECORD TRACK LED now remains on.

11) INPUT MONITOR LED

12) RECORD LED (Tracks 1 ~ 16 or 1 ~ 8)

13) INPUT MONITOR selector

a) If this switch is depressed, all channels will carry the input signal and LED (11) will light.

b) If this switch is not depressed, individual channels will monitor the input signal in the following way.

When the RECORD TRACK selector (10) is set to READY and when LED (12) is blinking, depressing the REC (6) button only will cause LED (11) to blink and the Model E-16 output for that channel only will change from TAPE OUT to INPUT.

c) Subsequent depressing of the REC (6) button will change the output signal from INPUT to TAPE OUT.

d) Should the REC button only be depressed when the RECORD TRACK selector (10) is at SAFE, LED (11) will blink but the output signal will not change to INPUT.

NOTE: While a given channel is in the RECORD mode, depressing the RECORD TRACK selector button for another channel will put that channel in the record mode and the output signal will change to INPUT.

14) Head assembly

15) Tape timer

A five digit counter to display the hour, minute and second. For position display below the zero point, a "-" is displayed in the hour digit.

Furthermore, as long as the pitch control knob (19) is touched by your finger, the display will change from tape counting to tape speed and the percentage against normal speed will be indicated.

16) RESET [0] button

The counter display is returned to zero by depressing this button.

17) Memory 1 button

The present time shown in the tape timer is stored in Memory 1 by depressing this button.

18) Memory 2 button

The present time shown in the tape timer is stored in Memory 2 by depressing this button.

- 19) Pitch control button knob [PITCH]
Tape speed can be varied approximately $\pm 15\%$ by the pitch control knob when the pitch control switch button is in the down position (left hand LED is lit).
Coarse adjustment is by the outer knob and fine adjustment by the inner knob.
- 20) Record LED [REC]
This LED will light green or red depending on the following conditions:
* With none of the RECORD TRACK buttons depressed, this RECORD LED will light green (record ready) when the RECORD and PLAY buttons are simultaneously depressed.
* With one or more RECORD TRACK buttons depressed, this RECORD LED will light red (recording) when the RECORD and PLAY buttons are simultaneously depressed.
This LED does not light during playback/search modes.
- 21) Cue lever
The lifter mechanism lifts the tape away from the heads in the REWIND and F.FWD modes.
The cue lever is provided to allow tape cueing when the tape is thus lifted from the head. Shifting the cue lever moves the lifter pins toward the head and the tape will touch the head. The cue lever will lock in position when it is fully shifted toward the head or the lock disengaged when it is pulled in the opposite direction.
- 22) Power switch [POWER]
AC power is applied to the unit and the tape timer will indicate zero when this button is depressed.
The capstan motor will not rotate unless the takeup reel tension arm is up --- unless the shut-off switch linked to the tension arm is on ---
- 23) Reel clamp
The reel is secured to the reel turntable by CW rotation of this clamp.
- 24) LED bargraph meter
These are peak reading meters. 0dB on the meter corresponds to a tape flux of 320 nWb/m.
- 25) INPUT jack
- 26) OUTPUT jack
- 27) NR INT/EXT switch [NR]
The internal Dolby noise reduction system operates when this switch is set to INT. The EXT position is for use with outboard noise reduction.
- 28) LOCATE 1/PLAY
The Model 8051 Foot Switch is plugged in here to control the Model E-16 (E-8). When the Model E-16 (E-8) is in the stop mode, stepping on the foot pedal puts the transport in PLAY mode.
When in modes other than stop, the function is the same as LOCATE 1, (7) above, whereby the Memory 1 tape position is searched in F.FWD or RWD and stopped at the objective point.
- 29) PUNCH IN/OUT switch
This switch is used with the Model 8051 Foot Switch to control the Model E-16 (E-8) record mode.
When the Model E-16 (E-8) is in the PLAY mode, stepping on the foot pedal once induces Punch-in; stepping on it again induces Punch-out.
With the Model 8316 plugged in and the transport in the RECORD mode, stepping on the foot pedal induces Punch-out.

30) ACCESSORY 1

The receptacle for connecting the Model 4030 Synchronizer, using the Model 8540 cable.

Please inquire at your nearest Fostex dealer or service station for details on the Synchronizer.

The Model 8031 Remote Tape Control Unit is also connected here.

31) ACCESSORY 2

This receptacle is for connecting the Model 4050 Autolocator, using the Model 8440 cable.

Please inquire at your nearest Fostex dealer or service station for details.

32) AC power cord

Model 8316 REMOTE CONTROL UNIT

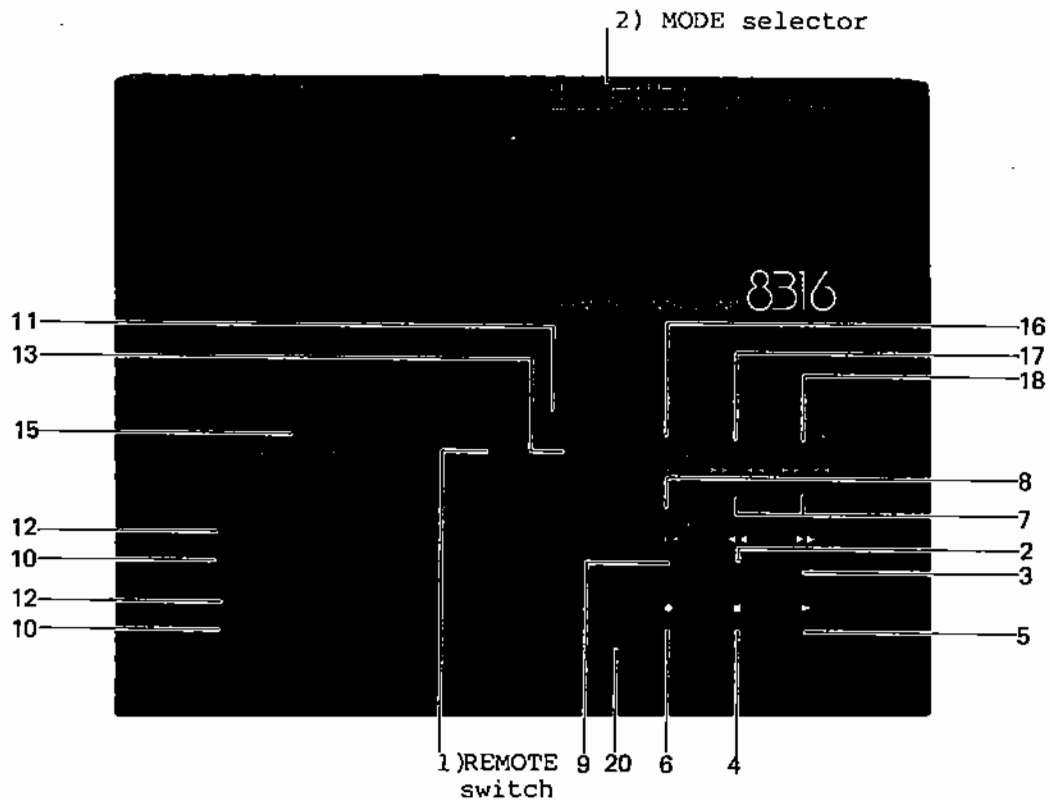

1) REMOTE switch

This is the switch to select whether the RECORD TRACK selector and the INPUT MONITOR selector are to be controlled, from the Model E-16 (E-8) or the Model 8316 REMOTE CONTROL UNIT. The RECORD TRACK selector and the INPUT MONITOR selector can be controlled from the REMOTE CONTROL UNIT when the REMOTE LED is lit. In this condition, the above operation cannot be controlled by the Model E-16 (E-8) buttons.

NOTE: Other control switches (buttons) will be operational from both, the Model E-16 (E-8) or the Model 8316 as they are wired in parallel.

2) MODE selector

This five point switch is set to the proper code representing the model number of the Fostex recorder to which the Model 8316 is connected.

Switch code	Applicable model
B	B-16 (Requires optional Model 8441 cable)
E/A	E-16, E-8, E-2, 80, 20
E-15 ips	E-16, E-8, E-22, E-2 at 15 ips tape speed
E-30 ips	E-22 at 30 ips tape speed
A	80, 20

For explanations on other than the above (1) REMOTE switch and (2) MODE selector, please refer to page 5 ~ 7.

NOTE:

1. Whenever the "MODE" switch setting is changed, always make sure to switch off the power supply once, then switching it on for the next operation.
2. When the Model 8316 is connected to the Model 20, E2, E22 be sure to set the Model 20's MONITOR SELECT to SYNC.
3. The RECORD TRACK indicating LED's will not light when REMOTE is "OFF."
4. Data for "0", "MEMORY 1" and "MEMORY 2" can be separately stored in the Model 8316 Remote Controller Unit from those in the recorder transport.
5. The SELECTOR LED on both E-16 and 8316 will be lit when the SELECT switch is depressed while the Model 8316 REMOTE switch is depressed.
6. When the Model 8316 MODE switch "B" is selected, it will be remote only for the B-16 and the separately sold Model 8441 cable is necessary.
7. The Model 8441 cable (separately sold) for use with the B-16 is directional which means the proper plug on the cable end must be plugged into the correct receptacle as shown below and must not be connected in reverse. Also, the cable included with the 8316 must not be used as it will damage the 8316.

Model 8441 cable

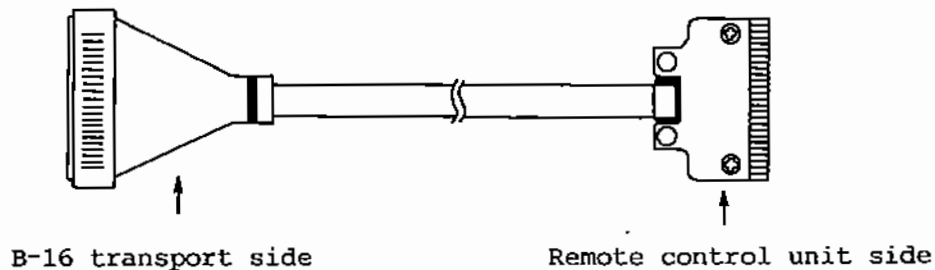

4. INSTALLATION

Unpack the unit and before making any electrical connections, inspect for any evidence of possible shipping damage. Save all packing materials at least until you have verified that the unit is working properly. If there is any evidence of damage due to rough handling, consult your Fostex dealer before connecting or operating the unit.

4.1 Installing the MB-16 Meter Bridge

If the E-16/E-8 is used horizontally, the meter can be viewed more easily by removing the meter section and mounting it on the Fostex MB-16 Meter Bridge as explained in the following.

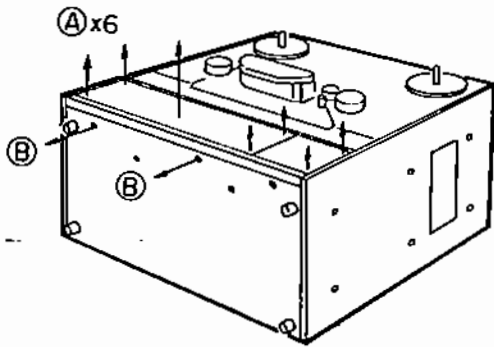

Step 1: Dismounting the E-16/E-8 meter section

* Using the hex wrench included with the E-16/E-8, remove the six cap screws (A), two self-tapping screws (B) and the meter panel can be removed.

* Swing the amplifier panel forward to 90 degrees.

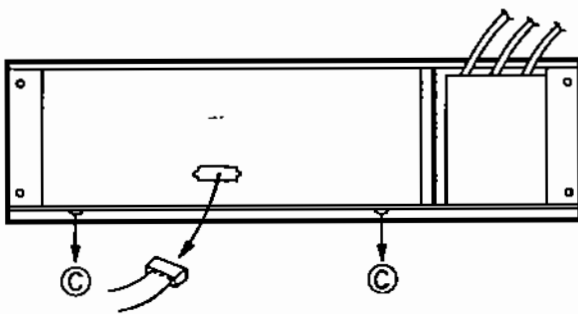
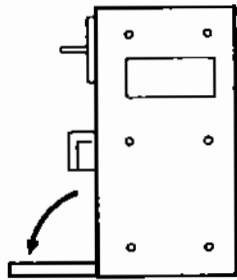

Step 2: Disconnect the 20p plugs inside the meter section, remove the two self-tapping screws (C), and lift out the meter section.

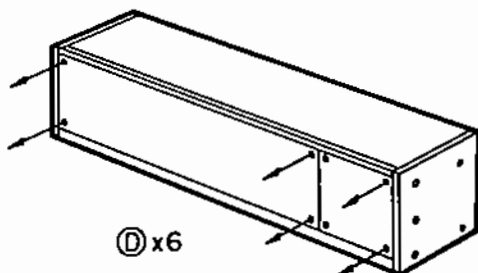

Step 3: Prepare the MB-16 Meter Bridge to accommodate the E-16/E-8 meter section by removing the filler panel.

* Remove the panel and panel unit by unscrewing the six cap screws (D).

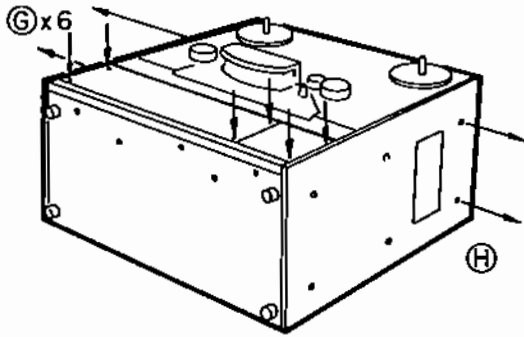

Step 4: Reinstall the six cap screws (G) and the single self-tapping screw (H).

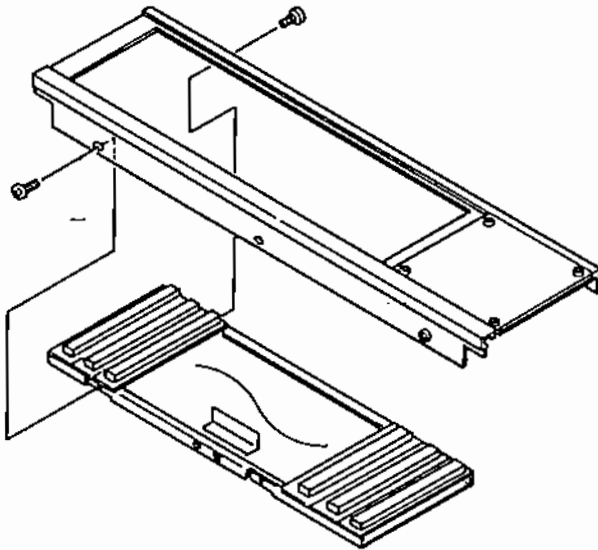

Step 5: Secure the meter unit into the MB-16 by the two self-tapping screws.

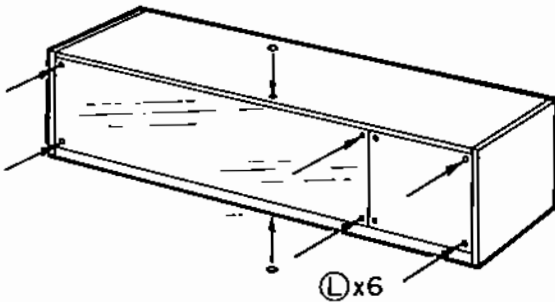

Step 6: The meter section is mounted in the MB-16 by the six cap screws (L) and, the unit and cover are secured by the two self-tapping screws.

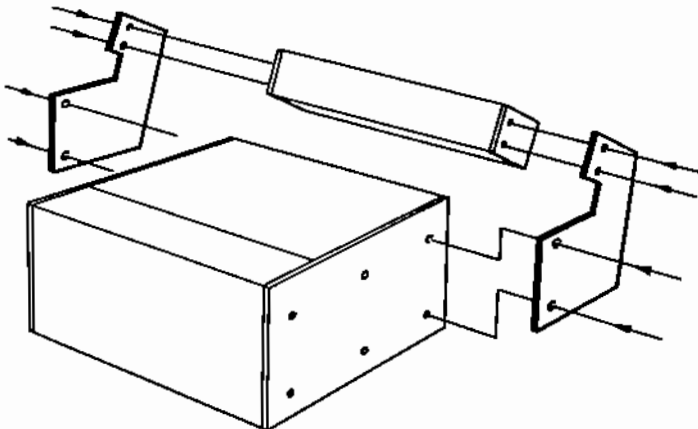

Step 7: After mounting the MB-16 on the E-16/E-8, the exclusive cable included with the MB-2 is used to interconnect between MB-16 and E-16/E-8.

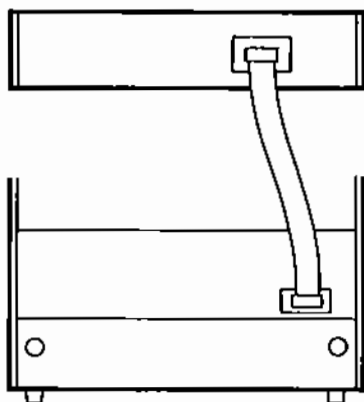

Step 8: Interconnect between the MB-16 and the E-16/E-8 by the cable included with the MB-16.

4.2 RACK MOUNTING

E-16/E-8 can be mounted in the Fostex Model 9081 console and on the EIA standard 19 inch rack. The Fostex Model 9905B Rack Mount Adaptor is recommended.

The rack mount adaptor is attached to the four holes on the E-16/E-8 transport side panel by the screws included with the 9905B. These four holes are hidden by plastic plugs which can be readily pierced by the screws.

NOTE: The Fostex Model 9907B Filler Panel is recommended to fill in the space above the E-16/E-8 at installing on the 19 rack.

4.3 CABLES

The E-16/E-8 has high impedance unbalanced inputs and outputs. It is recommended that all cables be kept to the shortest practical length, with a maximum of 10 feet (3 meters). Use only high quality cables with tightly braided shields, multiple-stranded center conductors, and low internal capacitance, such as Fostex Models 5044-5049.

Such cables minimize high frequency losses, and reduce susceptibility to hum. Separate the input cables from output cables by at least a few inches, and keep all signal cables as far away as practical, from AC power cords. If AC and signal cables must intersect, they should cross at right angles.

Microphones cannot be connected directly to the E-16/E-8 unless a microphone preamplifier is used to increase the signal level. However, many electronic musical instruments (e.g. electronic piano, synthesizer, etc.) can be connected directly to the recorder inputs.

4.4 RECORD INPUTS

The 16 (8) INPUT jacks are unbalanced, high impedance RCA type phono jacks which accept nominal -10dBV (0.3V) line level signals from a low or high impedance source. For +4dBm interface, we recommend the Fostex Model 5030.

CAUTION: Never connect a speaker-level output, such as the output of a power amplifier or guitar amplifier, to the E-16/E-8 INPUT jacks unless a suitable direct box is used. The direct box should attenuate the signal to a suitable -10dBV level, which prevents overdriving the recorder. The direct box also should include an isolation transformer, which avoids hum by preventing ground loops, and also avoids electrical shock hazard.

For synth players and programmers of electronic musical instruments, a line level 8x8x2 mixer, such as the Fostex Model 2050, and a 16-point normalled patch bay, such as the 3010, will prove to be incredibly functional and flexible. Once your system is patched, you'll be able to layer tracks, transfer, edit, ping-pong and mix - just by using jumper cables on the patch bay as you would assign switches on an expensive mixer. (Drum machines and many electronic instruments may be patched directly to the E-16/E-8.)

4.5 AC CONNECTIONS

Before plugging the recorder into an AC outlet, make sure the voltage and frequency are correct. It is usually a good idea to connect the mixer and the recorder to the same AC outlet, or at least the same leg of the AC service, as this minimizes any potential difference between chassis grounds in the equipment and thus minimize hum. This is especially important if the mixer and recorder both have grounded (3-prong) AC cords.

4.6 PLACEMENT AND MOUNTING CONSIDERATIONS

The E-16/E-8 can be operated in a vertical, horizontal or tilted position. Be sure that it is firmly supported, however, and that adequate ventilation space is provided. Also, be sure there is adequate clearance of the tape reels.

5. OPERATIONS

Practice each procedure by referring to the numbers of each control which are the same with those in Section 3, FEATURE DESCRIPTIONS.

5.1 Tape threading

Thread the tape as shown in Fig. 5.1 making sure the tape passes through the slit of the Tape Presence Sensor and that the Head Shield Gate is in the lowered position.

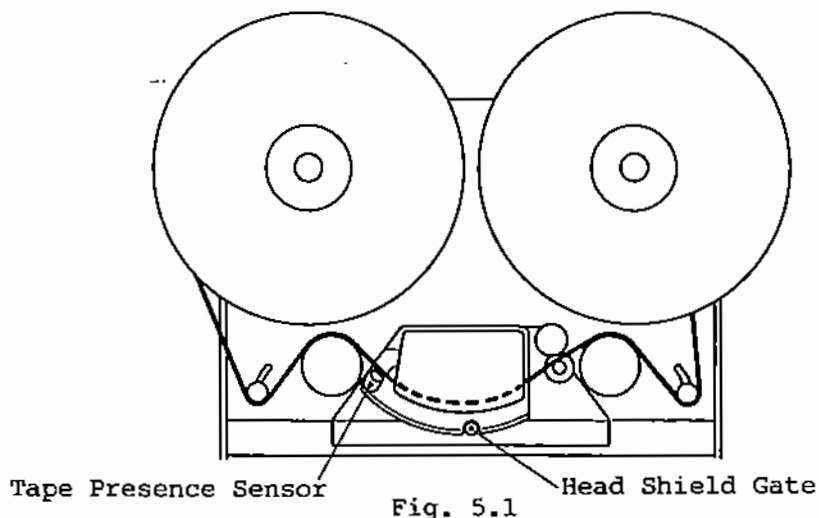

NOTE: The E-16 and E-8 are shipped from the plant with reel clampers already mounted. When using the 7 inch reel on the E-8, remove the reel clamber, install the reel, then replace the reel clamber and tighten it on the turntable shaft by the center clamber knob.

The 10 inch reel clamber will firmly lock the reel by rotating it about 60 degrees CW as shown in Fig. 5.2.

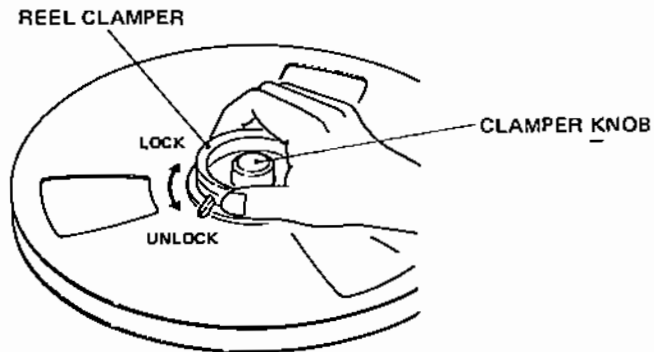

Fig. 5.2

CAUTION: Before putting the tape in motion, be sure the tape is taut with both left and right tension arms fully lifted.

5.2 Transport tape motion operation

- 1) When the PLAY button (5) is depressed, the capstan will begin to rotate, the pinch roller will be pulled against the capstan and tape will be transported at constant speed.

CAUTION: If the red LED at left of the PITCH control switch is blinking, this means the transport is NOT set to 15 ips normal speed but is set at "variable speed."

- 2) When the STOP button (4) is depressed, the pinch roller swings away from the capstan, the brakes are applied and the tape stops.
- 3) If the STOP button is depressed again, the left and right brakes are released, the tape will be stopped by balanced tension from both reels and thus, manual editing becomes possible by using CUE lever (21).
- 4) When the F.FWD (3) (REWIND/2) button is depressed, the tape lifter will push the tape away from the head surface and the tape will be transported at high speed from right (left) reel to the left (right) reel.

If the F.FWD (3) (REWIND/2) button is held down, tape will be transported at about 15 ips thus allowing fast forward/rewind shuttling of tape at editing work (This function is only for the E-8/E-16 main unit). It will return to the normal fast winding mode when your finger is released from the button.

Furthermore, the tape will be transported at about half speed of fast forward or rewind if the F.FWD (3) or REWIND (2) button and the PLAY button (27) are simultaneously depressed which is very suitable in neatly winding the tape.

- 5) If the AUTO PLAY button, then the LOCATE 0 (or LOCATE 1) button is depressed, the tape will momentarily stop at the ZERO (or MEMORY 1) position, then go into the PLAY mode.
- 6) The zone between MEMORY 1 and MEMORY 2 can be put in the repeat mode if the AUTO PLAY (8) and AUTO RTN (9) buttons are depressed beforehand. Care must be taken to maintain the MEMORY 1<MEMORY 2 relationship in the tape position memory when depressing the MEMORY 1 or 2 buttons. The counter display will blink to indicate an error when the relationship is MEMORY 1>MEMORY 2.

- 7) When the PLAY and RECORD (6) buttons are simultaneously depressed, any channel of the RECORD TRACK button that is depressed and in the READY mode, will enter the record mode and the RECORD LED will be lit. If all channels of the RECORD TRACK selector are set to SAFE, the RECORD LED will be lit in green and the tape will be transported in the record ready state.

5.3 TAPE IDENTIFICATION AND REFERENCE TONES

It is a good idea to use the first minute or two of recording time to record an identifying label (ID), stating the title, date, artist, noise reduction, and other pertinent information. Do this on all tracks. Whether or not a voice identification (ID) is recorded, many engineers like to record standard level reference tones so that during future playback of the tape, the recorder can be precisely aligned to yield identical frequency response and track-to-track levels. Follow the same steps outlined in the recording procedure (next) but before beginning to record the actual program, record the voice and/or tones. Use any suitable test oscillator (it can be routed through one of the mixer's input for easy assignment to all tracks). We suggest recording 20 seconds of each of the following tones at 0dB level:

1 KHz	(for checking the reproduce amp level)
10 KHz or 15 KHz	(for checking the high frequency EQ)
100 Hz or 50Hz	(for checking the low frequency EQ)

5.4 RECORDING INITIAL TRACKS

1. Typically, you'll record basic tracks as a reference for the overdubs.
2. Choose the specific track or tracks to be recorded by depressing the appropriate RECORD TRACK button(s) (10). The LEDs (12) above the track meter(s) will blink.
3. When the RECORD button (6) is depressed, the INPUT MON indicator (11) will blink and input signal of the channel whose RECORD TRACK button (11) is depressed, can be monitored at the recorder output and by the meter.
4. Press the RESET (16) button to zero the counter so it will be easy to return to the beginning of the recording.
5. Set levels with the mixer's master fader or buss output control so that the meters of those tracks to be recorded show peaks at +3dB to +6dB.
6. When ready to begin recording, simultaneously press the PLAY (5) and RECORD (6) buttons. (Alternately, press the PLAY button, then step on the REMOTE foot switch.)
7. To end the recording, press the STOP (4) button.

NOTE: One generally listens to the tracks as they are being recorded. This can be accomplished by monitoring the output from the mixer to the recorder, but a better approach is to set up the mixer so that it is monitoring all 8 outputs of the recorder. Then set up the recorder so that its outputs carry the signal(s) being recorded, as well as any previously recorded tracks. The recorder settings necessary are included in the following procedures.

5.5 CHECKING THE INITIAL TRACKS

1. Press the LOCATE 0 button (7) to rewind the tape.
2. Release the RECORD TRACK button(s) (10) to prevent accidental erasure of the track(s). The meters and output jacks will now carry the reproduce signal.
3. Press the PLAY button (5) and listen to the recording.

If the initial track(s) is acceptable, go on to the next procedure. If the initial track must be redone, simply repeat the initial recording procedure, re-recording on the same track will erase the previous "take." It is not usually necessary to re-record any identification or reference tones; just begin recording after the ID and/or tones.

5.6 RECORDING ADDITIONAL TRACKS (OVERDUBBING)

1. Return tape to zero position by depressing the LOCATE 0 (7) button.
2. Select the track(s) to be recorded using the RECORD TRACK selector button(s) (10).
3. When the RECORD button (6) only is depressed during STOP mode or PLAY mode, the signal at the OUTPUT jack (26) and the meter reading will be input monitor only for the track(s) selected in 2, above.
To cancel this mode, depress the RECORD button (6) only.
4. Set levels with the mixer's master fader or bus output control so that the meters of those tracks to be recorded show peaks at +3dB to +6dB.
5. When ready to begin recording, simultaneously press the PLAY (5) and RECORD button (6). (Alternately, press the PLAY button, then activate the REMOTE foot switch.)
6. To end the recording, press the STOP button (4).

5.7 Punch-in procedure

1. Rewind to a point prior to where the punch-in will take place.
2. Release all RECORD TRACK selector buttons (10) except for the track on which the punch-in is to be made; depress that RECORD TRACK button (10). The LED (12) above that track's RECORD TRACK button should blink.
3. If input monitor is desired, depress the RECORD button (6) only. The input monitor signal is then carried by the output jack and its level indicated by the meter of the channel whose RECORD TRACK selector (10) button is down.
4. Punch-in mode can be induced by either simultaneously depressing RECORD (6) and PLAY buttons (5) or stepping on the foot pedal for punch IN/OUT during PLAY mode.
5. Punch-out is induced, when in the RECORD mode, by stepping again on the foot pedal or by releasing the RECORD TRACK button (10).

5.8 PING PONG

"Ping pong" means the transfer of program material from one track to another on the tape to make room for later recordings. In its most common form, ping pong involves mixing together of two previously recorded tracks and simultaneously re-recording of that mix onto another unused track; the original two tracks may then be erased or used for subsequent overdubs. In a different form of ping pong technique, one or more "live" sources are mixed with one or two existing tracks, and this mix is re-recorded onto an unused track; once again, the original track(s) can then be erased.

CAUTION: There are a few limitations to which tracks can be transferred in any given ping pong. The limiting factor is signal leakage in the record/play head which could cause feedback (howling). PLAYBACK AND RECORD BETWEEN IMMEDIATELY ADJACENT TRACK(S) WITH GREAT CARE TO AVOID HOWLING.

5.9 OVER AND OVER

Whether in a Ping Pong recording, or any overdub, you're likely to encounter a section where you have to go back and forth, over and over,

until it's right. In this case, take advantage of the E-16 (E-8)'s multi-function transport circuitry.

Let's say you've recorded your basics and now you're ready to record background vocals (harmony parts, doubles) for the chorus. Simply set the Memory 1 mark at the beginning of the chorus, the Memory 2 at the end; then push the 1<<2 button (9). Whether before or after the selected chorus, press AUTO PLAY button (8) and the transport will find the beginning; play till the end, and then shuttle back and forth automatically until you tell it to stop.

You end up spending almost all of your time concentrating on your music, while your E-16 (E-8) takes predictable care of the cueing, all by itself.

5.10 MIXDOWN

Mixdown is the process whereby the 16 (8) track master tape is combined to stereo and transferred to a 2 track recorder. At this point, it is assumed that all 16 (8) tracks have been recorded, although you don't have to use all tracks.

The procedure, insofar as the E-16 (E-8) is concerned, is the same as normal playback. Be sure, however, that all RECORD TRACK selectors are released (SAFE mode).

5.11 SYNCHRONIZER USE

In addition to the Fostex Model 4030 Synchronizer, the Model E-16 (E-8) can be used with the majority of synchronizers on the market today, such as Audio-Kinetic's Q-Lock, Adams-Smith, BTX Shadow and EECO. In addition, many of the video editors can control the Model E-16 (E-8). The synchronizer port pin-out information is shown in the back of the Model E-16 (E-8) service manual. If you want to make your own cables, the connectors are available from our parts department.

The SMPTE time code is normally recorded on an edge track (usually track 16 (8)) at about 0 to -4 on the Model E-16 (E-8) bargraph meters. For proper time code reading, we cannot over-emphasize the importance of keeping the heads and the tape guides as clean as possible!

6. EDITING

Once a tape has been recorded, it may be necessary to rearrange the order of some takes, splice two different reels of tape together, or, to add leader tape between takes on a given tape. All these operations are considered to be editing. To edit a tape, one should have the following materials available:

1. A splicing block such as the Fostex Model 9931 (1/2") or 9930 (1/4").

This is usually made of aluminum, with a groove to hold the tape, and one or more grooves cut across the length of the block to guide the cutter.

2. A sharp, non-magnetic single-edged razor blade. To be sure the blade has no residual magnetism, it can be demagnetized in much the same way that the head assembly is demagnetized (Section 8). Be sure to hold the blade securely, however, since a demagnetizer may pull strongly on the blade.

NOTE: A magnetized razor blade will cause an audible "click" or "pop" at the point of the splice. Do not use scissors.

3. A sharp white or yellow grease pencil to mark the intended splice point on the back of the tape.

speed. Subsequent overdubs and/or the mixdown can be done either at standard speed or the modified speed, as desired.

7.3 SPEEDING UP A PERFORMANCE WITHOUT CHANGING THE PITCH

When a performer wishes to play a complex passage at a tempo that would normally be difficult, if not beyond his ability, the PITCH control can be put to good use.

The technique is best used during an overdub, where at least one recorded track is available for a frequency reference. When making the overdub, set the PITCH control so it slows down the tape (rotate CCW). The performer then plays in tempo with the slowed down tape. During this operation, be sure the instrument is tuned to the lower pitch heard in the monitors. For playback, return the PITCH control to the normal setting and set the PITCH control switch button (19) to up position. The overdub will now be heard in-tune, at normal pitch, and at a faster tempo than it was actually performed.

8. ROUTINE MAINTENANCE

Cleaning the heads and other parts in the tape path, demagnetizing this area, and checking the electronic alignment (bias, level and equalization) are necessary procedures, and should be done on a regular basis. Periodically, check the brake torque and pinch roller pressure.

8.1 CLEANING

Magnetic recording tape, no matter how good in quality, will always shed some of its oxide coating as it travels past the tape guides and head assembly. Whenever a small particle of oxide (or dust, dirt, hair, etc.) comes between the head and the tape, audible performance can be degraded, especially in the high frequencies.

If the oxide should be scraped off a portion of the tape backing, there will be a momentary loss of sound (a drop out). Drop outs are permanent flaws in the tape, and must be avoided. Clean guides and heads are less apt to scratch the tape.

An ideal solvent consists of 100% pure isopropyl alcohol. Rubbing alcohol should not be used; even though it is isopropyl, it usually contains water and oils which will leave an unwanted residue after cleaning.

CAUTION: Never use organic solvents such as methylethyl ketone (MEK), lacquer thinner, acetone, etc. These can dissolve the materials that bind the heads together, and, if spilled, can mar or deform plastic parts.

Wipe the heads, tension arm rollers, tape guides, pinch roller, and capstan with a common cotton swab, moistened with head cleaning fluid or alcohol. Allow the parts to air dry before threading a tape. (The process should be repeated until the swab no longer shows evidence of the reddish-brown oxide, and until the heads are shiny and clean.)

The exterior of the E-16/E-8 can be wiped with a cloth that is moistened with a weak detergent and water solution. Do not use solvents, oils, waxes or spray-on cleaners.

8.2 DEMAGNETIZATION

When a recording is made, the record/play head applies a powerful magnetic field to the tape. Iron oxide or similar magnetic particles in the recording tape store a portion of that magnetic field (this is the recording). It is a necessary law of physics that, as the recorded tape is subsequently played, some of the tape's magnetic field will be transferred to nearby metal parts. This residual magnetism is undesirable because it, in turn, can partially erase a tape. The purpose of demagnetizing (degaussing) is to neutralize residual magnetism in the vicinity of the tape path.

Demagnetizing with a device such as the Fostex Model 8180 is accomplished by bringing a strong alternating magnetic field (created by a demagnetizer) near the head area, then slowly withdrawing the field. It is very important that this procedure be done carefully, and there are no tapes within 2 feet (0.6 meters) of the demagnetizer when it is operating. It is also important to turn off the E-16/E-8 when the demagnetizer is turned on. Demagnetize after every 8 hours of use.

CAUTION: Demagnetizers are not dangerous devices but if used improperly, they can instantly erase a valuable tape, and can permanently magnetize metal parts - the opposite of the desired result. NEVER TURN ON OR EVEN PLUG IN A DEMAGNETIZER UNLESS IT IS AT LEAST 3 FEET (1 METER) AWAY FROM THE E-16/E-8. ALSO, NEVER TURN OFF THE DEMAGNETIZER UNTIL IT IS WITHDRAWN TO AN EQUAL DISTANCE OF AT LEAST 3 FEET. If the demagnetizer should be turned on or off nearby the E-16/E-8, it may impart a magnetic charge to the heads or tape guides which is too strong to be removed by the same demagnetizer.

8.3 CHECKING REPRODUCE ALIGNMENT

- 1) After cleaning and demagnetizing the transport, set the NR IN/OUT selector on the rear of the recorder to OUT, and thread a reproduce alignment tape on the recorder.

Reproduce alignment tape: Fostex Model 9200 (E-16), 9100A (E-8)
or, Magnetic Reference Lab., MRL 31J329 (E-16),
MRL 21J303 (E-8)

- 2) Be sure all RECORD TRACK selectors are released (SAFE mode), and INPUT MONITOR selector is in INDIV position. Then play the tape.
- 3) All 16 (E-16), or 8 (E-8) meters should indicate 0dB levels during the reference 1 KHz tone playback. If not, adjust the reproduce amplifier level (REP CAL, Fig. 6.1). Access to these adjustments is possible by swinging down the front panel of the recorder.
- 4) Similarly, during playback of the 100Hz and 10KHz tones, the meters should all indicate the level specified for the alignment tape. If not, adjust the playback equalization (REP EQ, Fig. 6.1).

NOTE 1: By removing the four screws, the amplifier panel hinged at the lower side, can be swung down to make adjustments from the front side.

NOTE 2: When using the MRL 31J329 or 21J303 tape, connect an AC voltmeter to the output of each channel at adjusting as the frequency response alignment level of this tape is -10dB.

4. A roll of 1/2" wide (1.3 cm) splicing tape. Splicing tape is specially manufactured for joining magnetic tape; it is thin, and has an adhesive that will adhere to the tape backing, yet not seep out of the splice under the typical pressures and temperatures encountered.

CAUTION: Never use conventional cellophane tape or packaging tapes for splicing. Some of the adhesive on such tapes may ultimately contaminate the recording tape, and may leave deposits on the tape heads and guides.

5. A supply of plastic or paper leader tape: plastic is stronger, but paper is easier to write upon with a pen or pencil, and is thus handy for making notes.

6.1 HIGH SPEED SEARCHING FOR AN EDIT POINT

You can search for the end of a take or the beginning of another take in either fast forward or rewind mode.

1. Turn down the monitor amplifier volume most of the way.
2. Press the REWIND (2) OR F.FWD button (3), and press the CUE lever (21) toward the head assembly so that the tape lightly rests on the record/play head.
3. A high pitched screech will be heard during the program, with a moment of silence at the end of the program; at that point, hit the STOP button (4). Since the tape will probably overshoot the intended edit point, it may be necessary to use the opposite fast wind mode momentarily, then press STOP (4) again.
4. For more precise location of the edit point, rewind slightly hold down the rewind button or fast forward button to find the exact edit point and press STOP (4). (NOTE: Return the monitor sound volume to normal, once fast-winding in cue mode has been completed. This procedure will protect your tweeters.)

7. CREATIVE USE OF THE PITCH CONTROL

The PITCH control can be used during recording or playback. Normally, these operations should be done with PITCH centered for two reasons, (a) tapes are made at calibrated speeds, and (b) the record/play equalization and the Dolby circuitry are properly aligned only at the normal running speed. There are instances when different speeds are useful.

7.1 RETIMING

If a recording has been made, say for a 60-second advertisement, and the overall program is a few seconds too short or too long, the PITCH control can be used during remixing to adjust the overall play time. The shift up or down in the frequency of the program should not be disturbing so long as a relatively small correction is used, say less than 5% (less than half the maximum speed deviation). A 5% speed change on a 60 second tape will add or subtract 3 seconds. In a longer program, say a 20 minute segment, a 5% change in length will amount to a full minute.

7.2 RETUNING

Suppose the initial track is recorded with the performer out-of-tune. During subsequent overdubs, it may be impractical or impossible to re-tune the instruments to match the detuned original track. In this case, adjust the PITCH control up or down so that the playback pitch equals the pitch of the instrument which cannot be retuned. Then make the overdub at that

8.4 CHECKING RECORD ALIGNMENT

- 1) After performing the reproduce check, thread a blank recording tape on the transport.
- 2) Depress all RECORD TRACK selectors (READY mode), and depress the INPUT MONITOR selector (ALL mode).
Apply a 1 KHz signal to the recorder inputs at nominal -10dBV level. The 16 (8) meters should indicate 0dB.
- 3) Record a length of 1 KHz tone, then play it back. If the level is not 0dB, adjust the record level (REC LEVEL) as required.
- 4) Reset the oscillator and record tones from 20Hz to 20KHz.
- 5) Playback the recording and check the frequency response. If it is not within the specified performance, adjust the recording equalization (REC EQ), and fine tune the bias (BIAS LEVEL) as necessary.

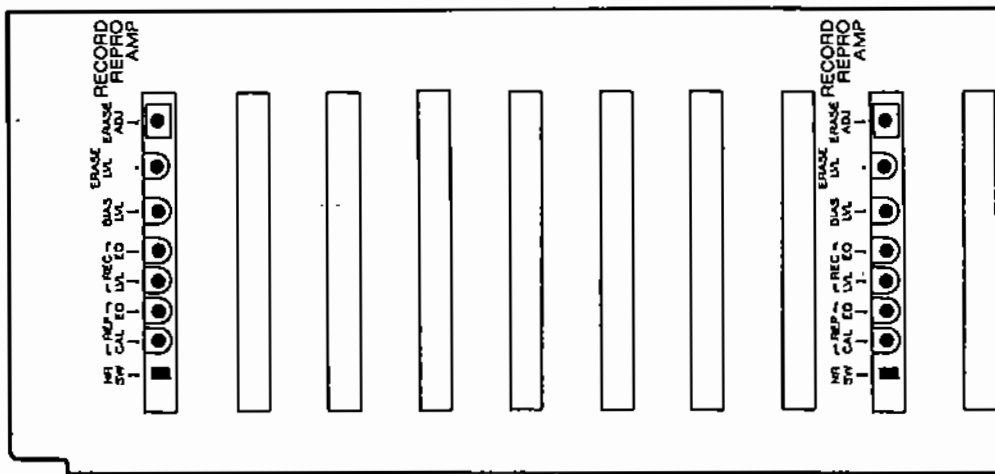

Fig. 6.1

8.5 CHECKING ERASURE

- 1) If erasure is not within specified performance, clean the tape path and after making sure tape travel is normal, adjust the ERASE LVL.
- 2) At adjusting the ERASE LVL, connect an AC voltmeter or oscilloscope to TP-4 and set to 300mV (rms) or 900mV (p-p).

CAUTION: Do not touch ERASE ADJUST as it is already adjusted at the plant before shipment.

SAFETY INSTRUCTIONS

WARNING

"READ BEFORE OPERATING"

1. Read Instructions—All the safety and operating instructions should be read before the appliance is operated.
2. Retain Instructions—The safety and operating instructions should be retained for future reference.
3. Heed Warnings—All warnings on the appliance and in the operating instructions should be adhered to.
4. Follow Instructions—All operating and use instructions should be followed.
5. Water and Moisture—The appliance should not be used near water—for example, near a bathtub, washbowl, kitchen sink, laundry tub, in a wet basement, or near a swimming pool, etc.
6. Ventilation—The appliance should be situated so that its location or position does not interfere with its proper ventilation. For example, the appliance should not be situated on a bed, sofa, rug, or similar surface that may block the ventilation openings; or, placed in a built-in installation, such as a bookcase or cabinet that may impede the flow of air through the ventilation openings.
7. Heat—The appliance should be situated away from heat sources such as radiators, heat registers, stoves, or other appliances (including amplifiers) that produce heat.
8. Power Sources—The appliance should be connected to a power supply only of the type described in the operating instructions or as marked on the appliance.
9. Power-Cord Protection—Power-supply cords should be routed so that they are not likely to be walked on or pinched by items placed upon or against them, paying particular attention to cords at plugs, convenience receptacles, and the point where they exit from the appliance.
10. Cleaning—The appliance should be cleaned only as recommended by the manufacturer.
11. Nonuse Periods—The power cord of the appliance should be unplugged from the outlet when left unused for a long period of time.
12. Object and Liquid Entry—Care should be taken so that objects do not fall and liquids are not spilled into the enclosure through openings.
13. Damage Requiring Service—The appliance should be serviced by qualified service personnel when:
 - A. The power-supply cord or the plug has been damaged; or
 - B. Objects have fallen, or liquid has been spilled into the appliance; or
 - C. The appliance has been exposed to rain; or
 - D. The appliance does not appear to operate normally or exhibits a marked change in performance; or
 - E. The appliance has been dropped, or the enclosure damaged.
14. Servicing—The user should not attempt to service the appliance beyond that described in the operating instructions. All other servicing should be referred to qualified service personnel.

Fostex

FOSTEX CORPORATION 3-2-35 Musashino, Akishima, Tokyo, Japan 196

FOSTEX CORPORATION OF AMERICA 15431, Blackburn Ave., Norwalk, CA 90650, U.S.A.

©PRINTED IN JAPAN JAN. 1988 B268 1180 00