



Professional Mixing Controller

**PCV-180**

**OWNER'S MANUAL**

Vestax Corporation  
1-18-6 Wakabayashi, Setagaya-ku, Tokyo 154-0023 Japan  
Phone 03-3412-7011 Fax 03-3412-7013  
Web : [www.vestax.jp](http://www.vestax.jp)

Vestax (Europe) Ltd.  
Unit 5 Riverway Industrial Park Aiton Hampshire GU34 2QL England, U.K.  
Phone (0)1420-83000 Fax (0)1420-80040  
Web : [www.vestax.co.uk](http://www.vestax.co.uk)

Vestax Europe Technical Support  
Rheinstr.213 D-53332 Bornheim Germany  
Phone 49(0)2222-95-23-72 Fax 49(0)2222-95-23-74

# CONGRATULATIONS!

Thank you for purchasing the Vestax PCV-180 Professional Mixing Controller. We suggest that you read through this owner's manual thoroughly so that you may enjoy the full use of this product safely and in the knowledge of all its special features and suitable applications.

## CONTENTS

<b>C A U T I O N</b>	.....	<b>2</b>
<b>IMPORTANT SAFEGUARDS</b>	.....	<b>3</b>
<b>F E A T U R E S</b>	.....	<b>4</b>
<b>F U N C T I O N S</b>	.....	<b>5</b>
<b>PROGRAM INPUT SECTION</b>	.....	<b>6</b>
<b>HOW TO CHANGE THE FADER UNIT</b>	.....	<b>7</b>
<b>MIC.MASTER SECTION</b>	.....	<b>9</b>
<b>REAR PANEL SECTION</b>	.....	<b>10</b>
<b>CONNECTIONS</b>	.....	<b>11</b>
<b>SPECIFICATIONS</b>	.....	<b>12</b>



### CAUTION

**RISK OF ELECTRIC SHOCK DO NOT OPEN**



**CAUTION : TO REDUCE THE RISK OF ELECTRIC SHOCK  
DO NOT REMOVE COVER (OR BACK)  
NO USER-SERVICEABLE PARTS INSIDE  
REFER SERVICING TO QUALIFIED SERVICE PERSONNEL**



The lightning flash with arrowhead symbol, within an equilateral triangle, is intended to alert the user to the presence of uninsulated "dangerous voltage" within the product's enclosure that may be of sufficient magnitude to constitute a risk of electric shock to persons.



The exclamation point within an equilateral triangle is intended to alert the user to the presence of important operating and maintenance (servicing) instructions in the literature accompanying the appliance.

**TO REDUCE THE RISK OF FIRE OR ELECTRIC SHOCK, DO NOT EXPOSE THIS APPLIANCE TO RAIN OR MOISTURE.**

# IMPORTANT SAFEGUARDS

## READ BEFORE OPERATING EQUIPMENT

This product was designed and manufactured to meet strict quality and safety standards. There are, however, some installation and operation precautions which you should be particularly aware of.

1. Read instructions-All the safety and operating instructions should be read before the appliance is operated.
2. Retain instructions-The safety and operating instructions should be retained for future reference.
3. Heed Warnings-All warnings on the appliance and in the operating instructions should be adhered to.
4. Follow Instructions-All operating and use instructions should be followed.
5. Cleaning-Do not use liquid cleaners or aerosol cleaners. Use a damp cloth for cleaning.
6. Attachments-Do not use attachments not recommended by the product manufacturer as they may cause hazards.
7. Water and Moisture-Do not use this product near water-for example, near a bath tub, wash bowl, kitchen sink, or laundry tub, in a wet basement, or near a swimming pool, and the like.
8. Accessories-Do not place this product on an unstable cart, stand, tripod, or table. The product may fall, causing serious injury to a child or adult, and serious damage to the appliance. Use only with a cart, stand, tripod, bracket, or table recommended by the manufacturer, or sold with product. Any mounting of the appliance should follow the manufacturer's instructions, and should use a mounting accessory recommended by the manufacturer.
9. This product should never be placed near or over a radiator or heat register. This product should not be placed in a built-in installation such as a bookcase or rack unless proper ventilation is provided or the manufacturer's instructions have been adhered to.
10. Power sources-This product should be operated only from the type of power source indicated on the marking label. If you are not sure of the type of power supply to your home, consult your appliance dealer or local power company.
11. Lightning-For added protection of this product during a lightning storm, or when it is left unattended and unused for long periods of time, unplug it from the wall outlet. This will prevent damage to the product due to lightning and power-line surges.
12. Overloading-Do not overload wall outlets and extension cords as this can result in a risk of fire or electric shock.
13. Object and Liquid Entry-Never push objects of any kind into this product through openings as they may touch dangerous voltage points or short-out parts that could result in a fire or electric shock. Never spill liquid of any kind on the product.
14. Servicing-Do not attempt to service product yourself as opening or removing covers may expose you to dangerous voltage or other hazards. Refer all servicing to qualified personnel.

15. **Damage Requiring Service**-Unplug this product from the wall outlet and refer servicing to qualified service personnel under the following conditions:
  - a. When the power-supply cord or plug is damaged.
  - b. If liquid has been spilled or objects have fallen into the product.
  - c. If the product has been exposed to rain or water.
  - d. If the product does not operate normally by following the operating instructions. Adjust only those controls that are covered by the operating instructions as an improper adjustment of other controls may result in damage and will often require extensive work by a qualified technician to restore the product to its normal operation.
  - e. If the product has been dropped or cabinet has been damaged.
  - f. When the product exhibits a distinct change in performance this indicates need for service.
16. **Replacement Parts**-When replacement parts are required, be sure the service technician has used replacement parts specified by the manufacturer or have the same characteristics as the original parts. Unauthorized substitutions may result in fire, electric shock or other hazards.
17. **Safety Check**-Upon completion of any service or repairs to product, ask the service technician to perform safety checks to determine that the product is in proper operating condition.
18. **Carts and Stands**-The appliance should be used only with a cart stand that is recommended by manufacturer.
19. An appliance and cart combination should be moved with care. Quick stops, excessive force, and uneven surfaces may cause the appliance and cart combination to overturn.



## FEATURES

- Stylish new body design.
- Advanced effects features with selectable pre/off/post positioning.
- Comprehensive headphone and monitoring features for reliable cuing in either split or stereo signal.
- 3-Band isolator with proprietary Vestax infinity cut.
- User upgradeable, serviceable and replaceable cross fader.
- Feedback preventative high density molded plastic body.
- 60mm long faders are provided for 3 program channels. More sensitive control can be achieved for Techno/Trance mixing.
- Effect send switch is equipped on each input channel for effect performance. The effect send and return level controls are provided in the master section.
- New superior grade crossfader (CF-PCV) fitted to PCV-180 enabling super smooth operation together with long life.

# FUNCTIONS

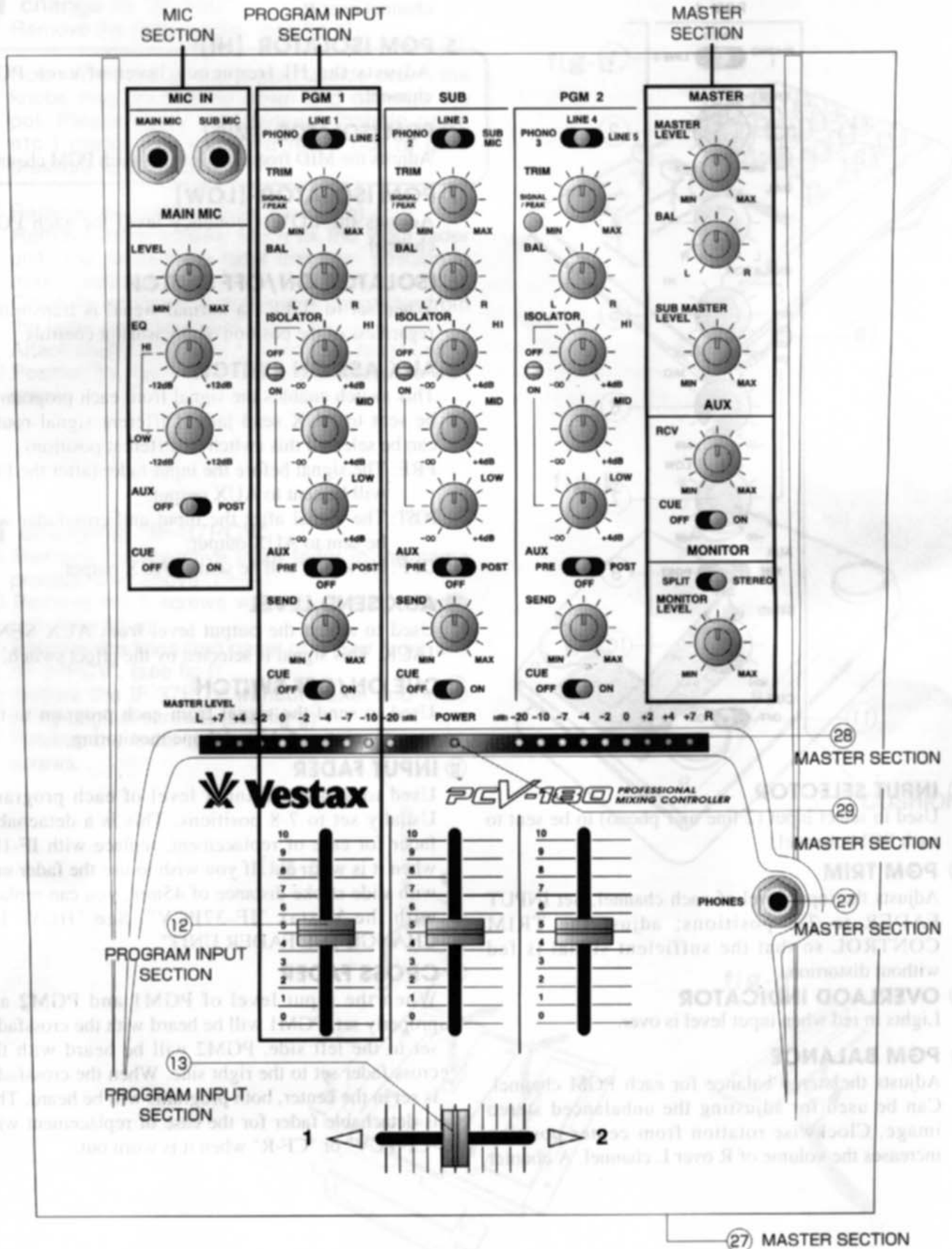

## PROGRAM INPUT SECTION

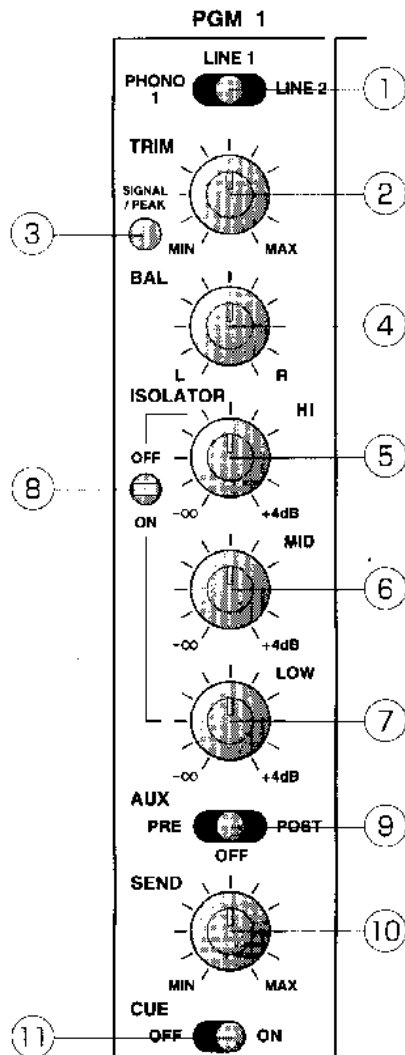

### ① INPUT SELECTOR

Used to select input (2 line or 1 phono) to be sent to each PGM channel.

### ② PGM TRIM

Adjusts the input level of each channel. Set INPUT FADER to 7-8 positions; adjust the TRIM CONTROL so that the sufficient signal is fed without distortion.

### ③ OVERLOAD INDICATOR

Lights in red when input level is over.

### ④ PGM BALANCE

Adjusts the stereo balance for each PGM channel. Can be used for adjusting the unbalanced stereo image. Clockwise rotation from center position increases the volume of R over L channel. A counter

clockwise rotation increases the volume of L channel over R.

### ⑤ PGM ISOLATOR [HI]

Adjusts the HI frequency level of each PGM channel.

### ⑥ PGM ISOLATOR [MID]

Adjusts the MID frequency level of each PGM channel.

### ⑦ PGM ISOLATOR [LOW]

Adjusts the LOW frequency level for each PGM channel.

### ⑧ ISOLATOR ON/OFF SWITCH

When set to "OFF", a normal signal is transmitted regardless of the position of any isolator controls.

### ⑨ AUX ASSIGN SWITCH

This switch enables the signal from each program to be sent to AUX send jack. Different signal routes can be selected this switch to different positions.

PRE: The signal before the input fader (after the EQ) will be sent to AUX output.

POST: The signal after the input and crossfader will be sent to AUX output.

OFF: No signal will be sent to AUX output.

### ⑩ AUX SEND LEVEL

Used to adjust the output level from AUX SEND JACK. This signal is selected by the effect switch.

### ⑪ CUE ON/OFF SWITCH

Used to send the signal from each program to the monitor section for headphone monitoring.

### ⑫ INPUT FADER

Used to adjust the Input level of each program. Usually set to 7-8 positions. This is a detachable fader for ease of replacement, replace with IF-180 when it is worn out. If you wish to use the fader unit with slide stroke distance of 45mm, you can replace with the Vestax "IF-37PCV". See "HOW TO CHANGE THE FADER UNIT".

### ⑬ CROSS FADER

When the input level of PGM1 and PGM2 are properly set, PGM1 will be heard with the crossfader set to the left side. PGM2 will be heard with the cross fader set to the right side. When the crossfader is set in the center, both programs will be heard. This is detachable fader for the ease of replacement with "CF-PCV" or "CF-R" when it is worn out.

## HOW TO CHANGE THE INPUT FADER UNIT

### ■ change to "IF-180"

- ① Remove the fader knobs. (see fig-a)

Note: When the unit is placed upside down, the knobs may be pushed down and damage the pot. Please apply soft material (baffle pack, etc.) under the unit and mind not to give pressure to the knobs.

fig-a

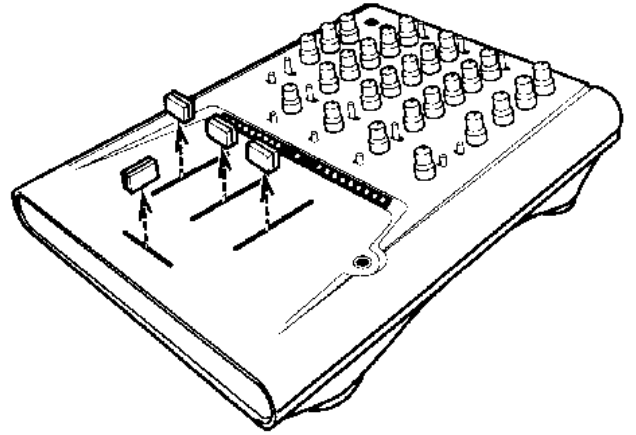

- ② Remove the bottom cover. (see fig-b)
- ③ Remove the 4 screws which fix the input fader unit, and remove the fader unit from position in mixer. (see fig-c)
- ④ Carefully remove the multi-cable connector from the fader unit. (see fig-d)
- ⑤ Attach multi-cable connector to new fader unit.
- ⑥ Position the fader unit carefully and secure with screws.

fig-b

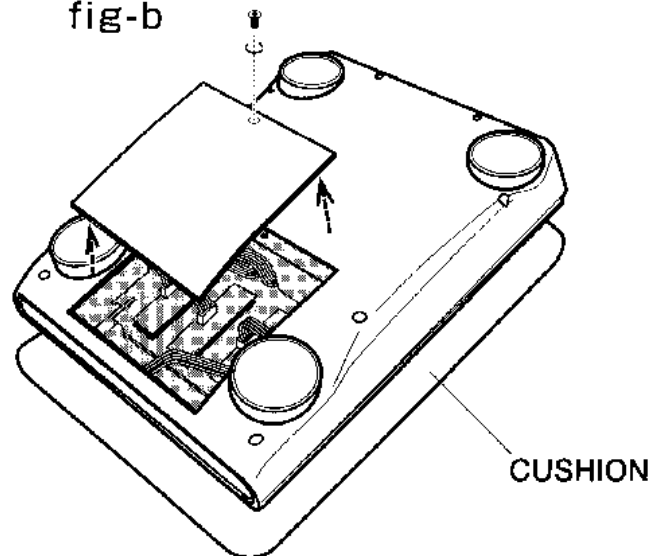

### ■ change to "IF-37PCV"

- ① Remove the objective input fader in the same procedure as above ①~④.
- ② Remove the 4 screws which fix the input-fader unit. (see fig-e)
- ③ Remove the knob and panel of a new fader unit "IF-37PCV". (see fig-f)
- ④ Secure the IF-37PCV without panel and knob using original screws. (see fig-g)
- ⑤ Position the fader unit carefully and secure with screws.

fig-c

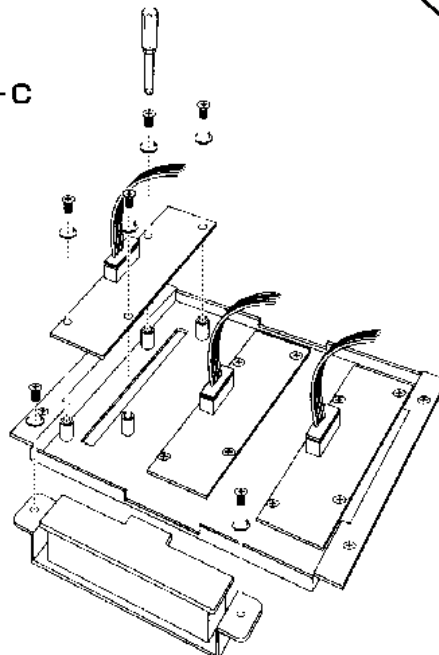
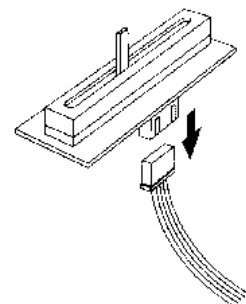

fig-d



# HOW TO CHANGE THE CROSS FADER UNIT

## ■ change to "CF-PCV"

- (1) Remove the fader knobs. (see fig-a)
- (2) Remove the bottom cover. (see fig-b)
- (3) Remove the 2 screws which fix the crossfader unit, and remove the fader unit from position in mixer. (see fig-c)
- (4) Carefully remove the multi-cable connector from the fader unit. (see fig-d)
- (5) Remove the screws which fix the crossfader volume. (see fig-h)
- (6) Remove the knob and the panel of new a new fader unit "CF-PCV". (refer to fig-f)

Note: Set switch to "PCV" position.

- (7) Secure the CF-PCV without panel and knob using original screws. Only 2 screws are used to secure the CF-PCV. (see fig-i)
- (8) Attach multi-cable connector to new fader unit.
- (9) Position the fader unit carefully and secure with screws.

## ■ change to "CF-R"

- (1) Remove the objective crossfader in the same procedure as above (1)~(5).
- (2) Remove the knob and the panel of a new fader unit "CF-R". (see fig-f)
- (3) Secure the CF-R without panel and knob using original screws. Only 2 screws are used to secure the CF-R. (see fig-i)
- (4) Attach multi-cable connector to new fader unit.
- (5) Position the fader unit carefully and secure with screws.

fig-e

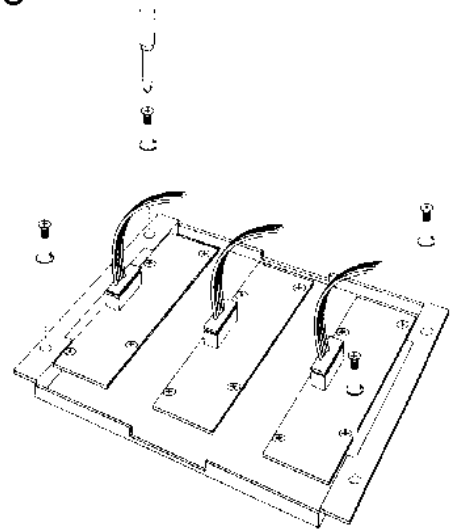

fig-f

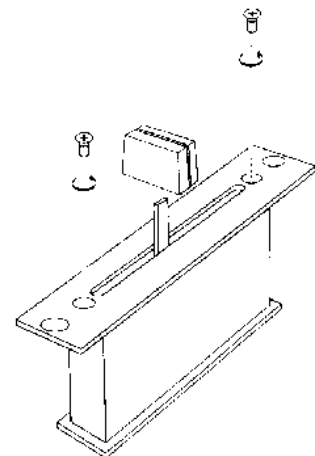

fig-g

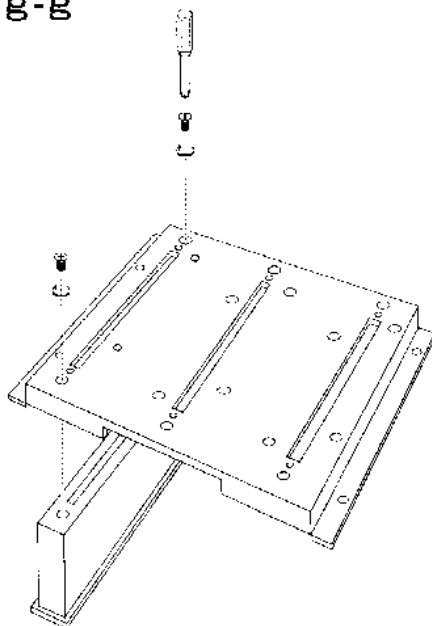

fig-h

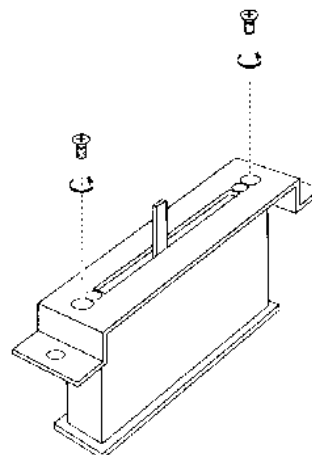
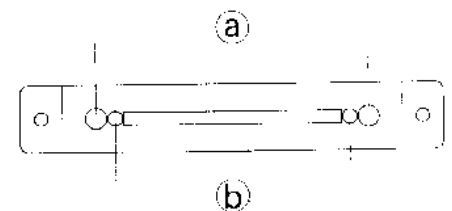
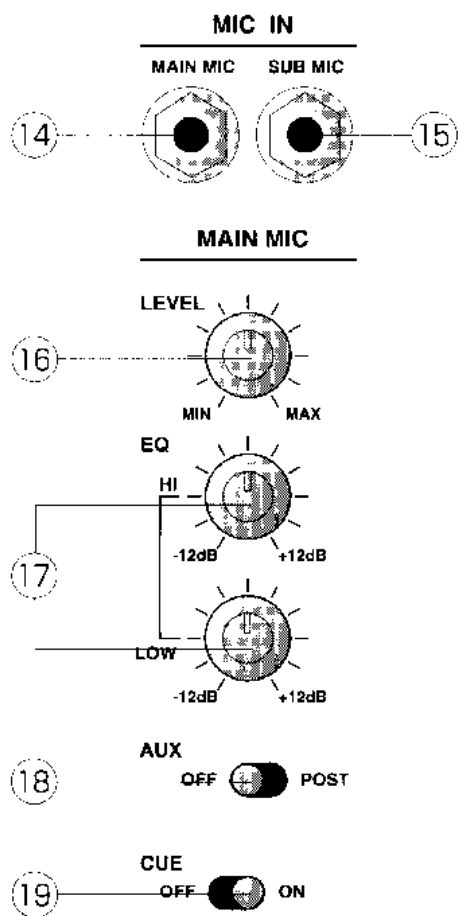

fig-i



(a): for "CF-PCV"  
(b): for "CF-R"

## MIC SECTION



- ⑭ **MAIN MIC IN JACK (1/4" PHONE JACK)**  
Input jack for MAIN MIC.
- ⑮ **SUB MIC IN JACK (1/4" PHONE JACK)**  
Input jack for SUB MIC.
- ⑯ **MAIN MIC LEVEL**  
Adjusts the input level of the MAIN MIC input.
- ⑰ **MAIN MIC EQ [HI, LOW]**  
Adjusts the HI and LOW frequencies for both the MAIN and SUB MIC input.
- ⑱ **MAIN MIC AUX ON/OFF SWITCH**  
Used to send the signal to the external effect processor connected to the AUX SEND.
- ⑲ **MAIN MIC CUE ON/OFF SWITCH**  
Used to send the signal from the mic channel to the monitor section for headphone monitoring.

## MASTER SECTION

- ⑳ **MASTER LEVEL**  
Adjusts the signal level of the master output.
- ㉑ **MASTER BALANCE**  
Adjusts the signal balance between left and right of the master output.
- ㉒ **SUB MASTER LEVEL**  
Adjusts the signal level outputs from SUB MASTER OUTPUT JACK on the rear panel.
- ㉓ **AUX RECEIVE LEVEL**  
Adjusts the output level from AUX RCV JACK.
- ㉔ **AUX RECEIVE CUE ON/OFF SW**  
Used to send the effect receive signal to the monitor section for the headphone monitoring.
- ㉕ **MONITOR STYLE SELECT SWITCH**  
When this switch is set to "SPLIT", the master signal is always heard through the right ear-cup of the headphones. The signal selected by MONITOR SELECT SWITCH will be heard in the left ear-cup. This enables both programs to be monitored simultaneously, thus assisting in beat mixing. When this switch is set to "STEREO", no master output is heard in the headphones, and only the signal selected by MONITOR SELECT SWITCH will be heard in both ear-cups.
- ㉖ **MONITOR LEVEL**  
Adjusts the headphone monitor level.
- ㉗ **HEADPHONE JACK**  
Connect the headphones with the impedance of 8ohm to 600 ohm.
- ㉘ **LED LEVEL METER**  
The LED bar level meters indicate the L and R outputs.
- ㉙ **POWER INDICATOR**  
Lights up when the POWER SWITCH is on.

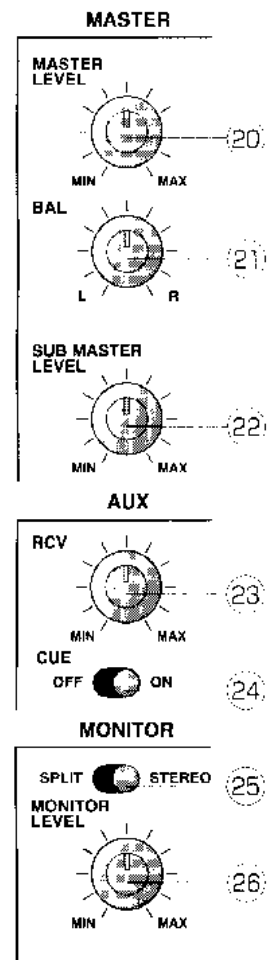

## REAR PANEL SECTION

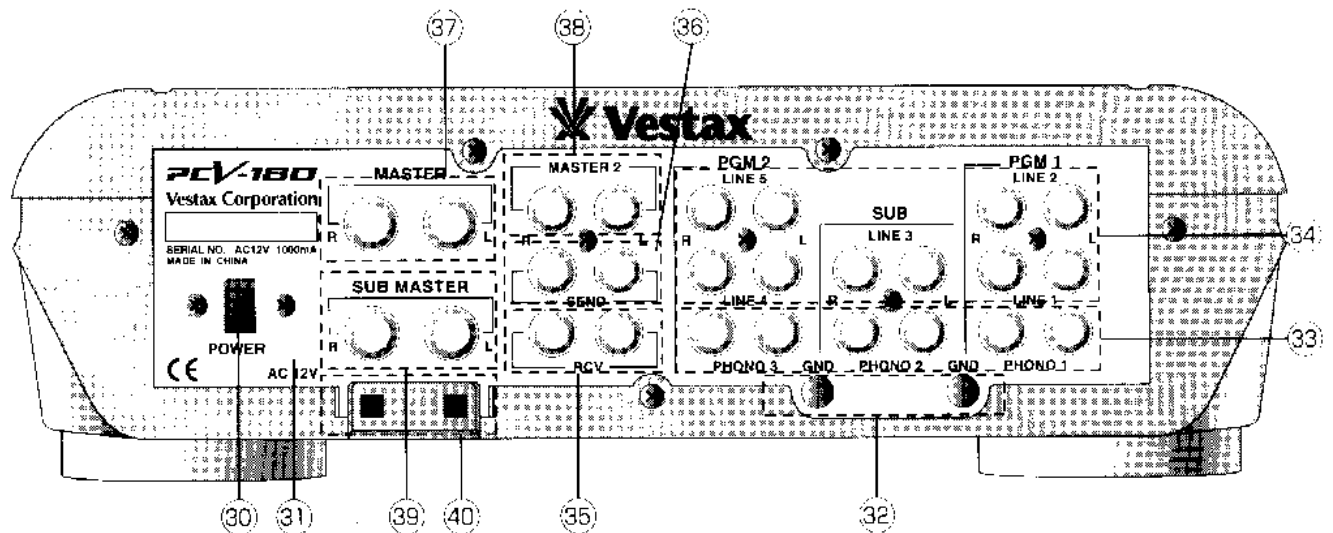

**30 POWER SWITCH**

Use to turn power on

**31 POWER INPUT JACK**

Connect the Vestax AC-12A, AC adaptor (12V AC, 1000mA).

**32 GROUND TERMINAL**

Connect this terminal to the ground lead of the turntables.

**33 PHONO INPUT JACK (RCA PIN JACK)**

Connect turntables equipped with MM (Moving Magnet type) cartridge. The signal from the turntable is fed to the PGM channels when Phono input is selected.

**34 LINE INPUT JACK (RCA PIN JACK)**

Connect the equipment with line level output (-10dB or 0dB), such as CD players, tape decks, DATs, MDs, etc. The signal from line level equipment is fed to the PGM channels when Line input is selected.

**35 AUX RECEIVE JACK**

Connect to the output of the external effects.

**36 AUX SEND JACK**

Connect to the input of the external effects. (Delay, Reverb etc)

**37 MASTER OUTPUT JACK**

Connect to the input of power amp

**38 MASTER 2 OUTPUT JACK**

The MASTER 2 jack is an unbalanced RCA output. The signal is same with master.

**39 SUB MASTER OUTPUT JACK**

Connect to input of power amp as monitor in DJ booth or as a separate sound zone for entrance foyer etc.

**40 ADPTOR CODE HOLDER**

Thread the power cable through this "holder" in order to prevent any accidental disconnection of power to the mixer.

# CONNECTIONS

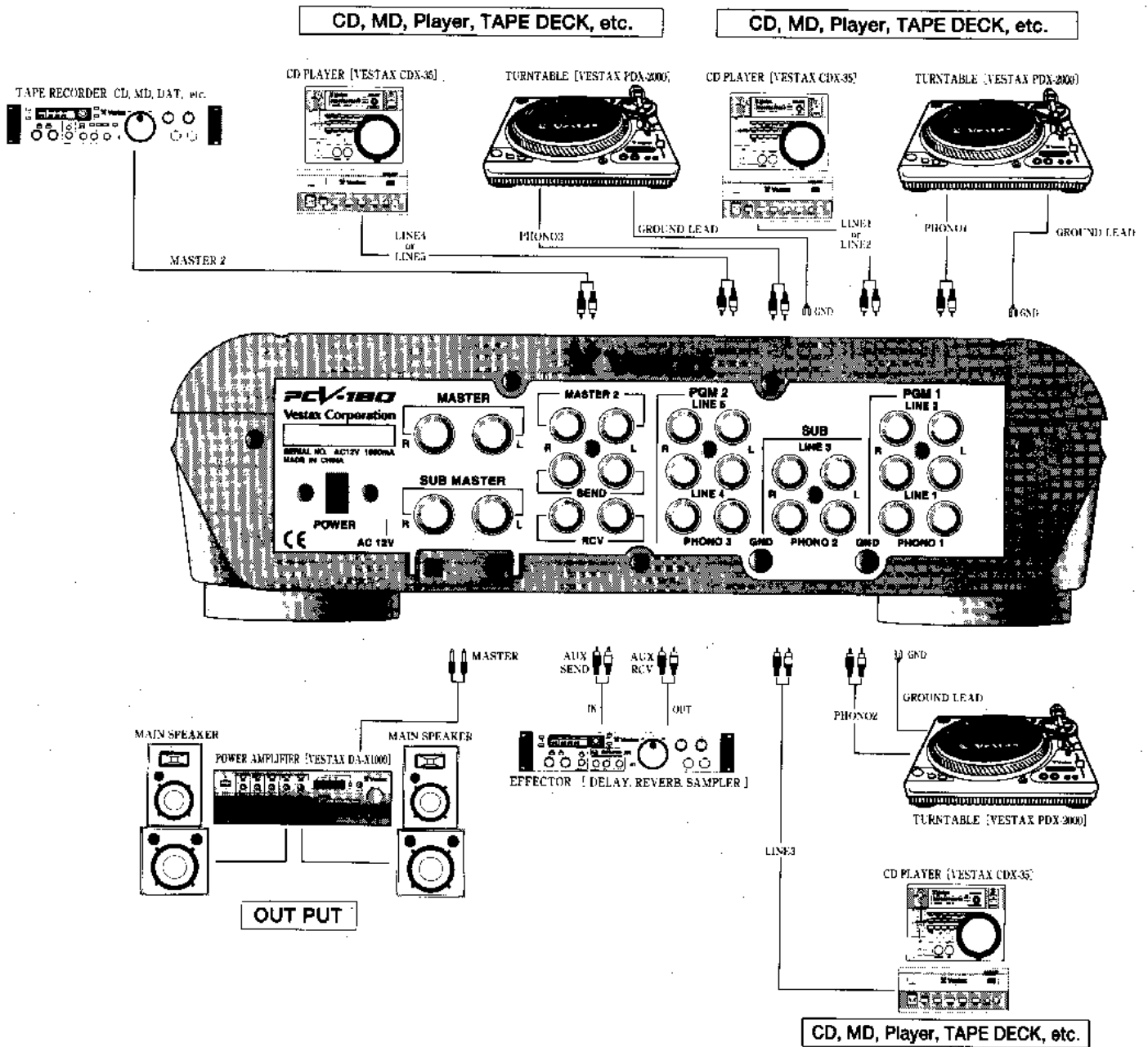

# SPECIFICATIONS

		NOMINAL INPUT LEVEL	MAXIMUM INPUT LEVEL	INPEDANCE
INPUT SECTION	MIC MAIN/SUB (1/4' PHONE JACK)	-50.0dBv	-32.0dBv	3.3k $\Omega$
	PHONO 1~3L/R (RCA JACK)	-46.0dBv	-22.4dB v	47k $\Omega$
	LINE 1~5L/R (RCA JACK)	-10.0dBv	+11.6dBv	47k $\Omega$
ISOLATOR SECTION	HI	10KHz - $\infty$ ~ +4dB		
	MID	1KHz - $\infty$ ~ +4dB		
	LOW	80KHz - $\infty$ ~ +4dB		
OUTPUT SECTION		RATED OUTPUT	MAXIMUM OUTPUT	INPEDANCE
	MASTER OUT L/R (1/4' PHONE JACK UNBALANCED)	0dBv	+11.4dBv	10k $\Omega$ OVER
	SUB MASTER OUT L/R (1/4' PHONE JACK UNBALANCED)	0dBv	+11.4dBv	10k $\Omega$ OVER
	MASTER2 L/R (RCA PIN JACK UNBALANCED)	0dBv	+11.4dBv	10k $\Omega$ OVER
	SEND OUT L/R (RCA PIN JACK UNBALANCED)	-10dBv	+11.4dBv	10k $\Omega$ OVER
	HEAD PHONE (1/4' PHONE JACK)	(47 $\Omega$ LOAD 130mW)		8~600 $\Omega$
FREQUENCY RESPONSE	MIC	30Hz ~ 20kHz $\pm$ 3dB	CROSSFADER CROSSTALK	> 65dB
	LINE	20Hz ~ 20kHz $\pm$ 1dB	CHANNEL CROSSTALK	> 75dB
S/N RATIO	MIC	>60dB	POWER SUPPLY	AC-12V ADAPTOR
	LINE	>75dB	DIMENSIONS (W×H×D)	330(W)×90(H)×406(D)
			WEIGHT	3.5kg



Vestax Corporation 1-18-6 Wakabayashi, Setagaya-ku, Tokyo 154-0023 Japan  
Telephone : 81-(0)3-3412-7011 Fax : 81-(0)3-3412-7013. www.vestax.jp

***This is to certify that the product subsequently referred to  
was designed and manufactured in conformity with the  
following EC directives;  
89/336/EEC (EMC)  
73/23/EEC (LVD)***

**Model type :** Professional Mixing Controller

**Model Description :** Professional DJ Mixer

**Model Number :** PCV-180

**Applicable Standards :** EN61000-3-2:2000 Electromagnetic compatibility (EMC) - Part 3-2: Limits - Limits for harmonic current emissions (equipment input current up to and including 16 A per phase)  
EN61000-3-3:1995 Electromagnetic compatibility (EMC) - Part 3-3: Limits - Limitation of voltage changes, voltage fluctuations and flicker in public low-voltage supply systems - Equipment with rated current <16 A per phase and not subject to conditional connection  
EN61000-6-1:2001 Electromagnetic (EMC) - Part 3-11: Limits - Limitation of voltage changes, voltage fluctuations and flicker in public low - voltage supply system - Equipment with rated current <75 A and subject to conditional connection  
IEC 61000-3-11:2000  
Relevant generic standard(s) Note 2.3  
EN61000-6-3:2001 Electromagnetic compatibility (EMC) - Part 6- 1: Generic standards - Immunity for residential, commercial and light - industrial environments  
IEC61000-6-1:1997 (modified)  
EN50082-1:1997 Note 2.1

**Date :** Wednesday, 27 May , 2003

**Place of issue :** Vestax Corporation, 1-18-6 Wakabayashi, Setagaya-ku,  
Tokyo 154-0023 Japan

**Manufacturers Authorized**

**Signature :**

Toshihide Nakama

**Function of Signatory :**

Director